

NEW

SMT Low-Profile Coaxial Multiple Contact Connectors

MRF03 Series

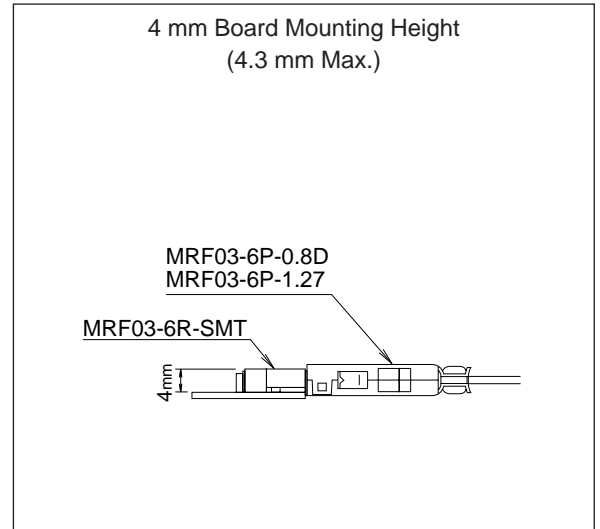
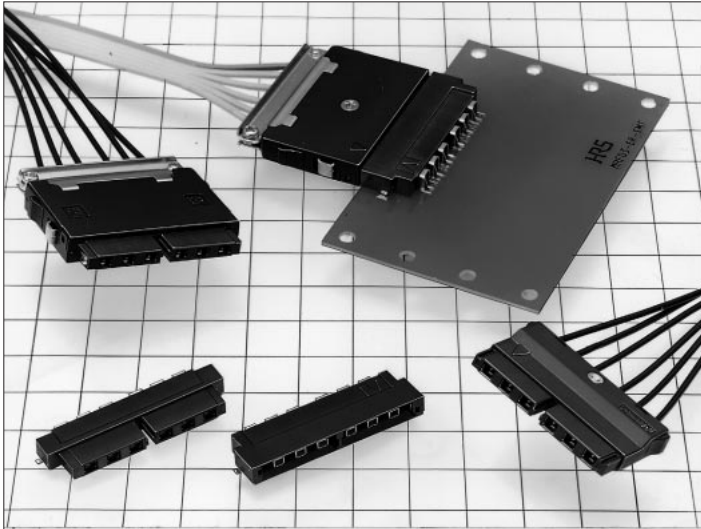

■ Features

1. Coaxial, Multiple Contact Type

6 coaxial contacts are built into the housing case and permits high-density mounting. The rectangular coaxial connector is also able to absorb shifts in pitch.

2. Connectors can be used with surface mount technology.

3. Low-Profile Connectors

The board mounting connectors have a mounting height of 4 mm from the board. (4.3 mm maximum)

■ Applications

50Ω: Equipment in the vicinity of base stations, such as portable telephones

75Ω: Large color LCD devices and image signal transmission

4. Two Locking Types Available

The locking types are available in a complete lock and a push-on lock type. The plug of complete lock type is equipped with lock springs on both sides which provides a sure lock sensation.

5. The high frequency characteristics correspond to both 50Ω and 75Ω types when the appropriate cable is used.

50Ω: DC to 1.7 GHz with a V.S.W.R. of 1.3 or less
75Ω: DC to 150 MHz with a V.S.W.R. of 1.2 or less

6. Connectors permit assembly of ultra-fine Teflon cable in conjunction with the characteristic impedance.

■ Function Diagrams

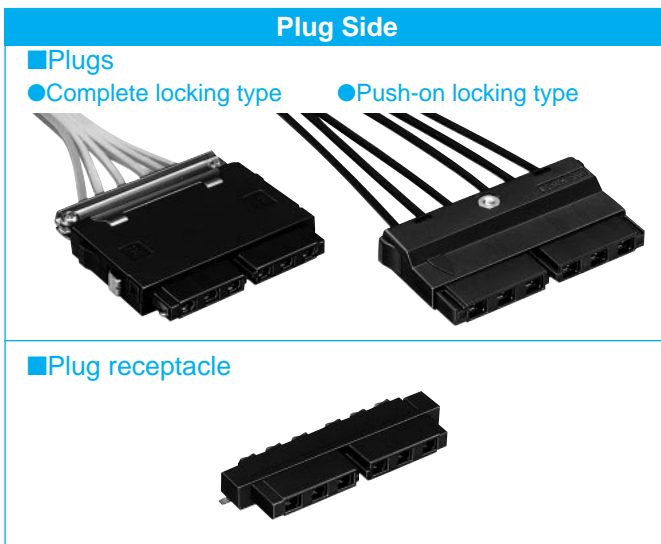

Standard Cable

Characteristic impedance	Cable name	Cable manufacturer	Cable type
50Ω	CO-6F-DSB-CX-50	Hitachi Cable, Ltd.	Discrete wire
	A12B0733-01	Junkosha Co., Ltd.	
75Ω	CO-6F-PFA-CX75	Hitachi Cable, Ltd.	1.27mm pitch flat cable
	UL20537 PF75VCAS		

UL20537 PF75VCAS, which is a 1.27mm pitch flat cable, allows easy wiring inside equipment.



Product Specifications

Ratings	Nominal characteristic impedance Frequency rating	50Ω and 75Ω 50Ω: 1.7 GHz 75Ω: 150 MHz	Operating temperature range Operating humidity	-30°C to +80°C 90% or less
---------	--	---	---	-------------------------------

Item	Specification	Condition
1. Contact resistance	Center : 35 mΩ or less Outside: 20 mΩ or less	Measured at 100 mA or less
2. Insulation resistance	500 MΩ or greater	Measured at 500 V DC
3. Withstand voltage	No line or insulation breakdown	500 V AC for one minute
4. V.S.W.R.(*)	50Ω: 1.3 or less 75Ω: 1.2 or less	Up to 1.7 GHz Up to 150 MHz
5. Female contact holding force	0.2 N or greater	Measured with a steel gauge of 0.29 width
6. Repetitive operation	Contact resistance Center : 40 mΩ or less Outside: 25 mΩ or less	50 cycles of insertion and removal
7. Vibration resistance	No momentary disconnections of 10 μs or longer No damage, cracks, or parts looseness	Frequency of 10 to 55 Hz, single amplitude of 0.75 mm, for 10 cycles in the direction of each of the 3 axes
8. Shock resistance	No electrical momentary disconnections of 10 μs or longer No damage, cracks, or parts looseness	Acceleration of 490 m/s ² , 11 ms duration, sine half-wave waveform, for 3 cycles in the direction of each of the 3 axes
9. Humidity resistance	Contact resistance Center : 35 mΩ or less Outside: 20 mΩ or less Insulation resistance 10 MΩ or greater	Temperature +40°C, Humidity 90 to 95%, let stand for 96 hours
10. Temperature cycle	Contact resistance Center : 35 mΩ or less Outside: 20 mΩ or less Insulation resistance 500 MΩ or greater	Temperature: -30°C → 5 to 35°C → 80°C → 5 to 35°C Time: 30 min. → Within 5 min. → 30 min. → Within 5 min. Cycles: 5
11. Salt spray test	No excessive corrosion	48 hours continuous exposure to 5% salt water

*V.S.W.R. Measurement System

The above V.S.W.R. standard values were measured using the measurement system of the diagram below.

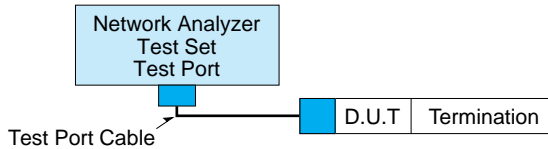

NOTE 1: Cable type connectors were measured with connectors attached to both ends of a suitable 25cm cable.

NOTE 2: Board type connectors were measured with connectors attached to a 50Ω and a 75Ω board.

Materials

Part	Material	Processing
Shell	Phosphor bronze	Contacts: Nickel plating Wiring portion: Solder plating
Insulator	Polyamide resin	Black (UL94HB)
Center contact	Phosphor bronze	Contacts: Gold plating Wiring: Solder plating
Case	PPS resin	Black (UL94V-0)
Reinforcement plate	Brass	Solder plating
Lock spring (NOTE)	Stainless steel	_____
Clamp (NOTE)	Stainless steel	_____

NOTE: Complete locking type plugs

Structure of the Product Number

This information is used to determine the product specifications from the product number expression.

At the time of ordering, select from the product number expressions on Pages 3 to 4 of this catalog.

[From among the plugs, when using UL20537 and PF75VCAS (flat cable for 75Ω use), cable assembly is performed only by HIROSE ELECTRIC CO., LTD. At time of ordering, please do so including the cable harness specifications.]

MRF03 - [1] - [2] - [3] - [4]

1	Series name: MRF03
2	Connector types 6P: 6-contact plug 6R: 6-contact receptacle 6PR: 6-contact plug receptacle
3	Suitable cable for plugs 0.8D: CO-6F-DSB-CX-50 (50Ω) A12B0733-01 (50Ω) CO-6FPFA-SB-CX75 (1X0.12) (75Ω) 1.27: UL20537 PF75VCAS (75Ω) For receptacles and plug receptacles SMT: Printed circuit board surface mounting type
4	Suffix

Plugs

Complete locking type

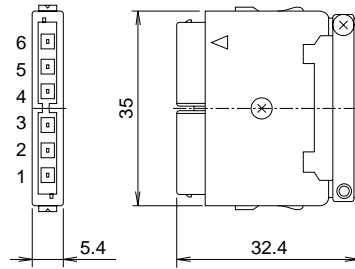
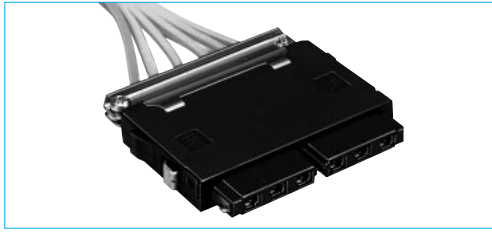

HRS No.	Product No.	Suitable Cable	
313-1006-3	MRF03-6P-0.8D	50Ω : CO-6F-DSB-CX-50 A12B0733-01	Manufactured by Hitachi Cable, Ltd. Manufactured by Junkosha Co., Ltd.
313-1001-0	MRF03-6P-1.27	75Ω : CO-6FPFA-SB-CX75 (1X0.12)	Manufactured by Hitachi Cable, Ltd.
		75Ω : UL20537 PF75VCAS	Manufactured by Hitachi Cable, Ltd.

NOTE: Please order MRF03-6P-1.27 with cable harness specifications.

Push-on lock type

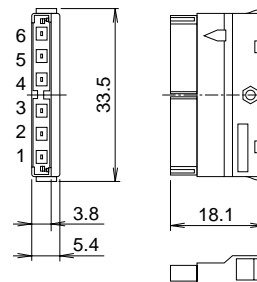

HRS No.	Product No.	Suitable Cable	
313-1008-9	MRF03-6P-0.8D-2	50Ω : CO-6F-DSB-CX-50 A12B0733-01	Manufactured by Hitachi Cable, Ltd. Manufactured by Junkosha Co., Ltd.
		75Ω : CO-6FPFA-SB-CX75 (1X0.12)	Manufactured by Hitachi Cable, Ltd.

Harness Products

Please specify dimensions of MRF03 Series harness specification products as described below.

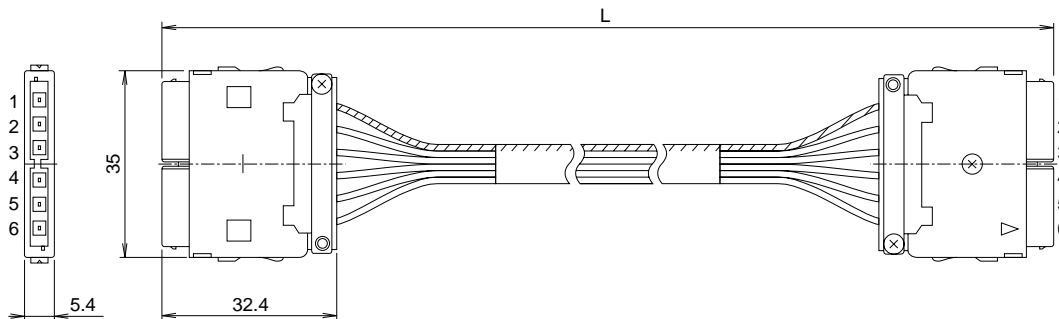

NOTE: Diagram numbers 1 through 6 indicate contact numbers. Note that indications do not appear on the connectors.

Structure of the product name of cable harness specification products

MRF03 – **2X6P** – **[]** – **[]**

① ② ③ ④

① Series name: MRF03	③ Suitable cable
② Connector type 2 x 6: Harness with 6-contact plug at both ends	④ Length L (mm)

NOTE: Please specify length L of flat coaxial cable UL20537 PF75VCAS harness specification products in units of 200 mm.
Recommended cable length (mm) L = 200, 400, 600, 800, 1000, 1200, ...

■ Plug Receptacles

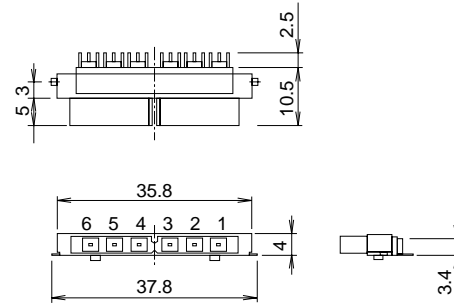
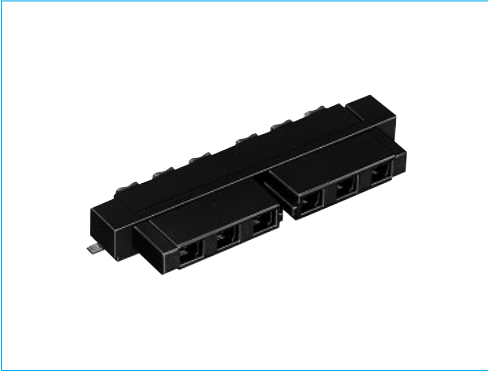

HRS No.	Product No.
313-1003-5	MRF03-6PR-SMT

■ Receptacles

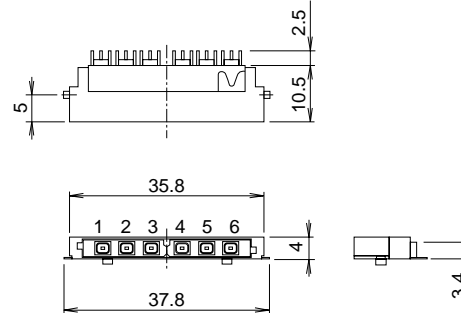

HRS No.	Product No.	Lock Type
313-1002-2	MRF03-6R-SMT	Complete lock
313-1007-6	MRF03-6R-SMT-2	Push-on lock

■ Recommended Board Pattern Diagram

● Receptacles and plug receptacles

A screen thickness of 0.15 to 0.25 mm is recommended for cream printing.

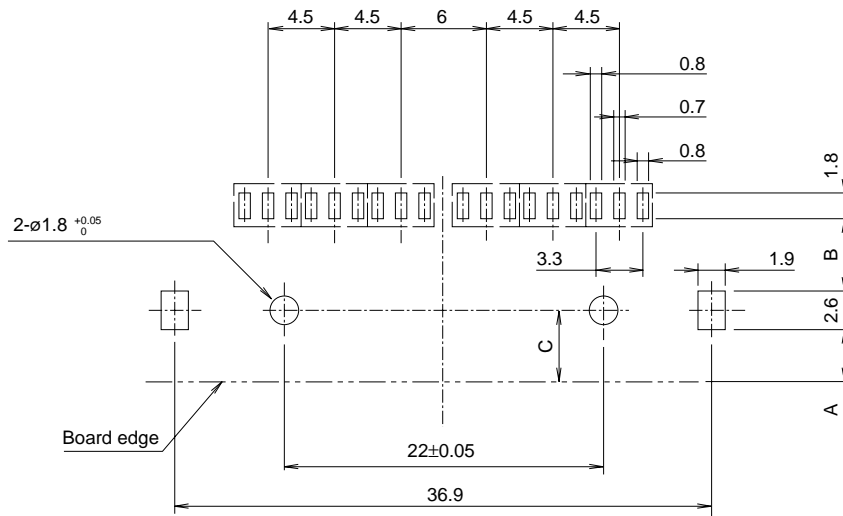

Product Number	Dimensions (mm)		
	A	B	C
MRF03-6R-SMT	3.7	5.2	5±0.05
MRF03-6R-SMT-2			
MRF03-6PR-SMT	1.7	2.2	2±0.05

Usage Precautions

1. Plugs

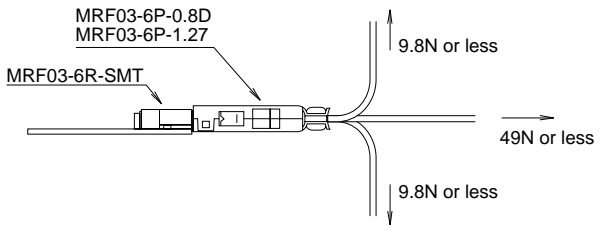
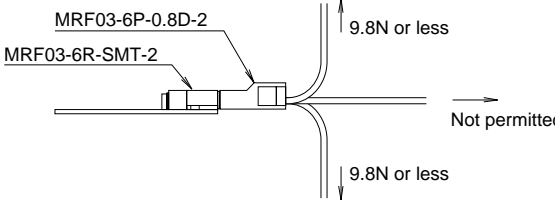
<p>(1) Insertion and removal of connectors</p>	<p>Be sure to check the polarity mark before mating the connectors. Attempting to forcefully mate the connectors in reverse will ruin or scrape the connectors.</p>
<p>(2) Permissible load placed on the cable after the connectors are mated</p>	<p>1) After the connectors are mated, do not apply a load to the cable in excess of the value indicated in the diagram below.</p> <div style="display: flex; align-items: center;"> <div style="margin-right: 20px;"> <p>● Complete lock type MRF03-6P-0.8D MRF03-6P-1.27</p> </div>  </div> <div style="display: flex; align-items: center; margin-top: 20px;"> <div style="margin-right: 20px;"> <p>● Push-on lock type MRF03-6P-0.8D-2 MRF03-6R-SMT-2</p> </div>  </div> <p>Pulling the cable of the push-on lock type results in the disconnection of the connector.</p>
<p>(3) Precautions</p>	<p>These connectors are not suited for external interfaces. Note that insertion or removal using excessive twist will result in damage.</p>

2. Receptacles and Plug Receptacles

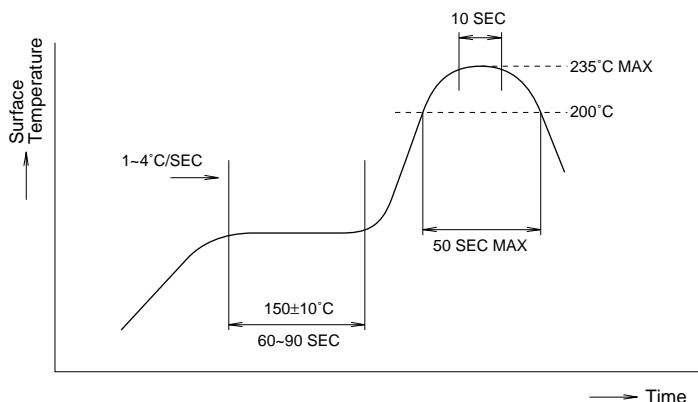
<p>(1) Recommended temperature profile (Reference)</p>	 <ol style="list-style-type: none"> 1) Permitted up to two times with the same conditions; however, there must be a period at room temperature between the first and second times. 2) The temperature indicates the board surface temperature at the connector lead portion. 3) Reflow soldering should be performed at a peak temperature of 240°C or less at the surface of the printed circuit board. 4) The temperature profile will change depending on such factors as the size of the board, the solder used, and the solder thickness.
<p>(2) Recommended hand soldering conditions</p>	<p>Soldering iron temperature: 350°C, Soldering time: Within 5 seconds</p>
<p>(3) Precautions</p>	<ol style="list-style-type: none"> 1) A special tray is used in the packaging of these connectors. Application of excessive force to the contacts will result in misshaped contacts and the soldering quality will be lost at the time of reflow soldering. For these reasons, dropping or rough handling of the product should be avoided. 2) Be careful not to misshape the contacts or fittings if the connectors are inserted or disengaged before soldering.